

SCAN-LINE 80 AND 80XL

OPERATING AND INSTALLATION INSTRUCTIONS



Congratulations on your new stove. We are sure that you will be happy with your investment, especially if you follow the advice and instructions we have put together in these operating instructions. Scan-Line 800 combustion chamber, and are therefore approved, like the Scan-Line 800, under EN 13240, DINplus, 15 a B-VG and NS 3058/3059. Approval means that consumers can be sure, that the stove meets a range of

specifications and requirements intended to ensure that the materials used are of good quality, that the stove does not adversely affect the environment, and that it is economical to use.

With your new stove you should have received the following:

- a. Operating instructions
- b. A stove glove

INSTALLATION INSTRUCTIONS

Safety clearances

Stoves must always be installed in line with national and, if applicable, local regulations. It is important to abide by local regulations regarding setting up chimneys and connection to same. Therefore, always consult your local chimney sweep before installation, as you are personally responsible for ensuring that the applicable regulations have been met.

Distance regulations

A difference applies to installation next to flammable and non-flammable walls. If the wall is made of non-flammable material the stove can, in principle, be placed flush against it. However, we recommend leaving a gap of at least 5 cm to facilitate cleaning behind the stove. **The minimum distances to flammable material are stated on the boiler plate and are listed in the table on page 7.**

Warning



A stove gets hot. (In excess of 90 degrees) Take care to ensure that children can not come into contact with it. Combustible materials should not be stored in the compartment below the ashpan.

IMPORTANT

1. Make sure there is adequate provision to sweep the chimney.
2. Make sure there is adequate ventilation to the room.
3. Please note that any extraction fans operating in the same room as the wood-burning stove can reduce the chimney draft – which may have an adverse effect on stove combustion properties. In addition, this may cause smoke to be emitted from the stove when the firing door is opened.
4. It must not be possible to cover any air vents.

The floor

It is essential to ensure that the floor surface can actually bear the weight of the stove and a top-mounted steel chimney, if applicable. The stove must stand on a nonflammable surface such as a steel floor plate or a brick or tile floor. The size of the nonflammable surface used to cover the floor area must match national and local regulations.

The chimney connection

The chimney opening must follow national and local regulations. However, the area of the opening should never be less than 175 cm², which corresponds to a diameter of 150 mm. If a

damper is fitted in the flue gas pipe, there must always be at least 20 cm² of free passage, even when the damper is in its “closed” position. If local regulations permit, two contained fire-places can be connected to the same chimney. However, you must abide by local regulations regarding the distance between the two connections.

Wood-burning stoves must never be connected to chimneys that are also linked to a gasfired heater. An efficient stove makes high demand on chimney properties – so always have your local chimney sweep evaluate your chimney.

Connection to a brick chimney

Brick a thimble into the chimney and seat the flue gas pipe in this. The thimble and flue gas pipe must not penetrate the chimney opening itself, but must be flush with the inside of the chimney duct. Joins between brickwork, the thimble and flue gas pipe must be sealed with fireproof material and/or beading

Connection to a steel chimney

When fitting a connection from a top-output stove directly to a steel chimney, we recommend fitting the chimney tube inside the flue gas spigot so that any soot and condensation drops into the stove itself rather than collecting on the exterior surface of the stove. Changing smoke outlet from top-mounted to rear-mounted (see fig. 10+11 on page 12).

For connections to chimneys that are run through ceilings, all national and local regulations regarding distance to flammable material must be followed. It is important that the chimney is fitted with roof support so that the top panel of the stove is not required to bear the entire weight of the chimney (excessive weight may cause damage on or noise from the stove).

Draft conditions

Poor draft may result in smoke being emitted from the stove when the door is opened. The minimum chimney draft to ensure satisfactory combustion in stoves of this kind is 13 PA. However, there will still be a risk of smoke emission if the firing door is opened during powerful firing. The flue gas temperature at nominal output is 274°C when expelled to an exterior temperature of 20°C. The flue gas mass flow is 5.1 g/sec. The chimney draft is generated by the difference between the high temperature of the chimney and the low temperature of the fresh air. The length and insulation of the chimney, wind and weather conditions also have an effect on the ability of the chimney to generate appropriate under-pressure.

If the stove has not been used in a while, check that the chimney and stove are not blocked with soot, bird nests, etc., before using it.

Reduced draft can occur when:

- The difference in temperature is too small – due to insufficient chimney insulation, for example.
- The outdoor temperature is too high – in summer, for example.
- No wind is blowing.
- The chimney is too low and sheltered.
- The chimney contains false air.
- The chimney and flue gas pipe are blocked.
- The house is too airtight (i.e. when there is an insufficient supply of fresh air).
- Poor smoke extraction (poor draft conditions) due to a cold chimney or bad weather conditions can be compensated for by increasing the airflow into the stove.

Good draft occurs when:

- The difference in temperature between the chimney and outdoor air is high.
- The weather is fine.
- The wind is blowing strongly.
- The chimney is of the correct height: at least 4.00 m above the stove and free of the roof ridge.

INSTRUCTIONS FOR USE

First firing

The stove has been treated with a heat-resistant coating which hardens at a temperature of approximately 250 °C. This hardening process causes the production of smoke and malodorous fumes, so the room must be very well ventilated. During the first firing, which should be carried out using approximately 1.5 kg. of wood, the stoking door must be opened slightly every 10 minutes for the first two hours to prevent the sealing rope sticking to the stove.

Fuel

Your new stove is EN approved for firing with wood fuel. You must therefore only burn clean, dry wood in your stove. Never use your stove to burn driftwood, as this may contain a lot of salt which can damage both the stove and the chimney. Similarly, you must not fire your stove with refuse, painted wood, pressure-impregnated wood or chipboard, as these materials can emit poisonous fumes and smoke. Correct firing using well seasoned wood provides optimal heat output and maximum economy. At the same time, correct firing prevents environmental damage in the form of smoke and emissions and also reduces the risk of chimney fires. If the wood is wet and inadequately seasoned, a large proportion of the energy in the fuel will be used to vaporise the water,

and this will all disappear up the chimney. Thus it is important to use dry, well seasoned wood, i.e. wood with a moisture content of no more than 20%. This is achieved by storing the wood for 1–2 years before use. Pieces of firewood with a diameter of more than 10 cm should be split before storing. The pieces of firewood should be of an appropriate length (approx. 25 cm) so that they can lie flat on the bed of embers. If you store your wood outdoors, it is best to cover it.

Examples of recommended woods types

and their typical specific gravity per cubic meter stated as 100% wood with a moisture content of 18%
Set

Wood	kg/m ³	Wood for fire	kg/m ³
Beech	710	Alder	540
Ash	700	Scotch pine	520
Elm	690	Larch	520
Maple	660	Lime	510
Birch	620	Spruce	450
Mountain pine	600	Poplar	450
Willow	560		

It is advised not to use very oil-containing woods like teak tree and mahogany, as this can cause damage to the glass.

Heating value in wood

You have to use about 2.4 kg normal wood to replace one litre of heating oil. All woods have almost the same heating value per kg, which is about 5.27 kW/hour for absolute dry wood. Wood with a moistness of 18% has a efficiency of about 4.18 kW/hour per kg, and one litre heating oil contains about 10 kW/hour.

CO₂ release

At combustion 1000 litres of heating oil forms 3.171 tons CO₂. As wood is a CO₂ neutral heat/ energy source, you save the environment about 1.3 kg CO₂ every time you have used 1 kg normal wood.

Chimney fires

In the event of a chimney fire – which often results from incorrect operation or protracted firing with moist wood – close the door and shut off the secondary/start-up air supply to smother the fire. Call the fire department.

Airflow regulation

The combustion air flow is controlled by the handle at the top right, as shown on fig. 1.

The combustion air flow is fully open when the handle is as far back as possible. Combustion air is gradually reduced by moving the handle forward, and is completely shut off when it reaches the front position.

Fig. 1

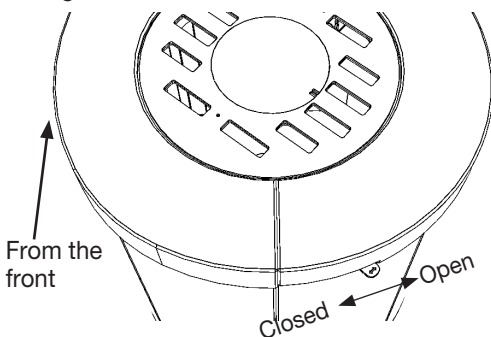

Lighting the stove

To light the stove, use firelighters, paraffin firelighter bags or small pieces of wood. Place over the grate. Place larger logs over the fire-lighting material, at right angles to the door. Turn handle to top position for max. Combustion- airflow. The stove door should be slightly ajar (about 1 cm). When the wood is well lit and the chimney is hot (after about 10 minutes), close the stove door. When lighting the stove from cold, we recommend that the combustion airflow is at maximum until the first stack of wood has burned out so that the stove and chimney are heated through.

Adding fuel

A fresh supply of fuel should normally be added while there is still a good layer of hot embers. Spread the embers over the base grate, most towards the front of the stove. Lay a single layer of wood fuel corresponding to about 1.5 kg over the embers, at right angles to the stove door. Turn handle into top position (max. Combustion- airflow). Keep door ajar if necessary. (The door should not be left open but fuel will ignite more quickly while the door is ajar.) The wood should ignite within a very short time (usually 1-3 minutes). If the door is ajar, close it as soon as the fuel is ignited. When the flames spread across the fuel stack, adjust the combustion airflow to the required level. Nominal operation 5.5 kW corresponds to 70% combustion airflow. When adding fuel, make sure that the fuel is not too tightly packed, as this will lead to poorer combustion and fuel inefficiency. Never fill firewood over the stove's max. fill line. See fig. 2.

Fig. 2

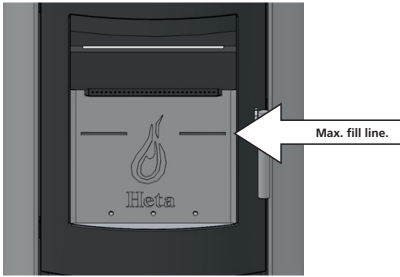

Reduced rate of combustion

The stove is suitable for intermittent use. If you require a lower rate of heat effect, fill the combustion chamber with less wood. Allow lower combustion airflow. Do not forget that the combustion airflow must never be completely closed when lighting up. It is important to maintain the layer of embers. Low-effect heating is achieved when the wood is glowing, i.e. there are no more flames because the wood fuel has been transformed into glowing charcoal.

Optimal combustion

For optimal combustion and heating, this stove is designed to provide an optimum mix of primary and secondary air (in these instructions, we call this combustion air). The stove provides excellent heating efficiency

and the window is easy to maintain as the secondary air 'flushes' the surface of the glass. Note that the stove will, of course, blacken if the airflow is too low. If there is too little oxygen, there is a risk that the window, etc. will blacken due to the formation of soot deposits. A combination of incorrect combustion and damp wood fuel can cause a heavy, sticky coat of soot to form, which may cause the door seal to tear off next time the door is opened.

Risk of explosion

 **After you add new fuel, it is very important that you do not leave the stove unattended until the wood is burning constantly. This will normally occur within 30 to 60 seconds.**

A risk of explosion can possibly arise if too much wood is placed in the stove. This may result in the production of large volumes of gas, and this gas can explode if the intake of primary and secondary air is insufficient.

It is an advantage always to leave some ash lying in the bottom of the combustion chamber.

Take care when emptying the ash pan, as cinders can continue to burn in the ash for long periods of time.

PURPOSE OF THE CONVECTION VENT

Stoves in the Scan-Line 80 series are radiated-heat stoves, which use several kilograms of soapstone and stone mass to store heat. You can get even more out of the stored heat by regulating the convection air flow. Once the stove has heated up, pull out the convection vent as shown in Fig. 3 to close the vent and prevent any more air from flowing through the stove. The stove will then release the heat slowly into the room over the next several hours.

Fig. 3

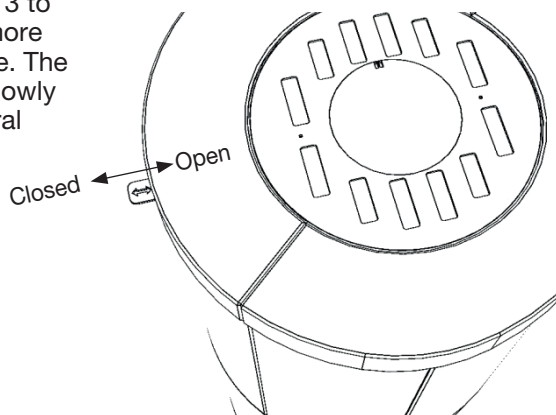

Stove data table in accordance with EN 13240 testing.

Stove type Scan-Line series	Nominal fluegas temperature c°	Smoke stub mm	Fuel volume kg	Draught min mbar	Nominal output tested kW	Heat output %	Distance to flammable materials in mm		Distance to furnitures from the stove in mm	Stove weight kg
							behind the stove	at the sides		
SL 80 soapstone	274	ø150	1.5	0.13	5.5	79	125	300	900	266
SL 80 ceramics	274	ø150	1.5	0.13	5.5	79	125	300	900	206
SL 80 XL soapstone	274	ø150	1.5	0.13	5.5	79	125	300	900	395
SL 80 XL ceramics	274	ø150	1.5	0.13	5.5	79	125	300	900	271

The nominal output is the output to which the stove has been tested. The test was carried out with the secondary air 80% open.

OPERATIONAL PROBLEMS

The chimney must be swept at least once a year, we recommend the use of a NACS (national association of chimney sweeps) registered chimney sweep. In the event of smoke or malodorous fumes being produced, you must first check to see whether the chimney is blocked. The chimney must, of course, always provide the minimum draught necessary to ensure that it is possible to regulate the fire. Please note, however, that chimney draft is dependent on the weather conditions. In high winds, the draft can become so powerful that it may be necessary to fit a damper in

the flue gas pipe to regulate the draft. When cleaning the chimney, soot and other deposits may come to fall on the smoke turning plate. In cases where the wood burns too quickly, this may be due to excessive chimney draught. You should also check to make sure that the door seal is intact and correctly fitting.

If the stove is generating too little heat, this may be because you are firing with wet wood. In this case, much of the heating energy is used to dry the wood, resulting in poor heating economics and an increased risk of soot deposits in the chimney.

MAINTENANCE

The surface of the stove has been treated with heat-resistant paint. The stove should be cleaned with a damp cloth. Any damage to the surface in the form of chips or scratches can be repaired using touch-up paint, which is available in spray cans.

Cleaning the glass

Incorrect firing, for example using wet wood, can result in the viewing window becoming covered in soot. This soot can be easily and effectively removed by using proprietary stove glass cleaner.

Cleaning and repairing soapstone surfaces

Soapstone is a relatively soft natural product. It is therefore possible to repair scratches or other damage to the surface.

Cleaning soapstone surfaces

Clean soot, grease, etc. from surfaces using water and soft soap or similar.

- Spread the soap on the surface
- Let it stand a few minutes
- Rinse off the surface using hot water
- Once the surface is dry you can sand it gently if necessary using sandpaper (120 grit)

Minor scratches and impact marks

Gently sand using sandpaper (120 grit) until the scratches are gone. It is a good idea to use a sanding block. To maintain a uniform surface on the stone, the entire surface should be gently sanded at the end.

Chipped surfaces

This section covers more serious damage, such as if a piece has chipped off or is missing. If the chipped off piece is intact, it can be glued in place using 'waterglass' (available from Heta A/S). Apply waterglass to the surfaces, clamp in place for 24 hours, then sand using sandpaper (120 grit). If a piece is missing or an impact mark is deep, you can repair the damage using a mix

of soapstone powder and waterglass (available from Heta A/S). Mix the powder and waterglass to an appropriate consistency. Clean off any dust before applying the mixture. Brush the surface with waterglass to ensure good adhesion. Apply the soapstone mixture generously, as it contracts during hardening. Do a repeat application if necessary.

The hardened surface can be sanded after 24 hours. Use 60-80 grit sandpaper initially, and then 120 grit sandpaper to finish.

Cleaning ceramic surfaces

The ceramics have a glazed surface and can be wiped with a damp cloth.

GUARANTEE

The model Scan-Line 800 stoves are subjected to stringent quality control procedures both throughout the production process and immediately before delivery to the dealer. Therefore, the stoves are guaranteed against defects in manufacturing FOR FIVE YEARS.

This guarantee does not cover: Wearing parts/fragile parts such as:

- The fire-proof bricks in the combustion chamber.
- The smoke baffle
- The glass
- The sealing rope
- The grate frame

Damage resulting from incorrect use
Transport costs in connection with repairs carried out under guarantee
Installation/disassembly in connection with repairs carried out under guarantee. Should you have cause to make a complaint, please quote our invoice no.

Warning



Any unauthorised modification of the stove and any use of non-original spares will void the guarantee.

CONNECTING EXTERNAL AIR SUPPLY (OUTSIDE AIR)

The stove allows connection to outside air through a Ø 100 mm inlet

An aluflex Ø 100 mm hose is recommended (available from Heta), which can handle temperatures up to 200° C

Fig. 4 illustrates the two options – downwards or backwards.

Fig. 4

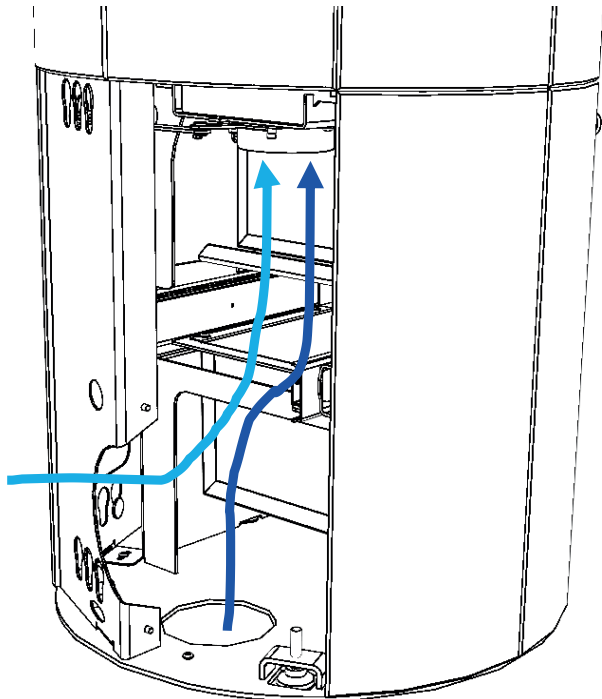

Emptying the ash pan, fig. 5-9

The ash pan is located behind the large pull-out front (see fig. 5) and is emptied as shown in fig. 6-9. NB! Be sure to correctly orient the ash pan, otherwise it will not close properly.

Fig. 5

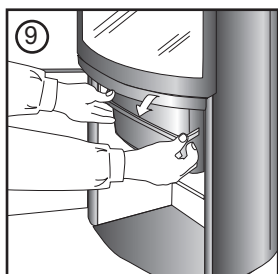
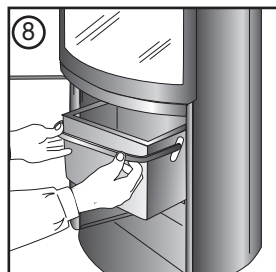
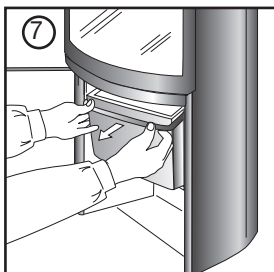
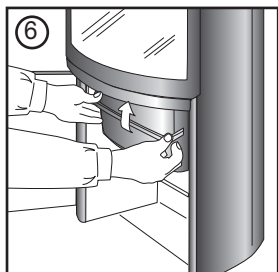
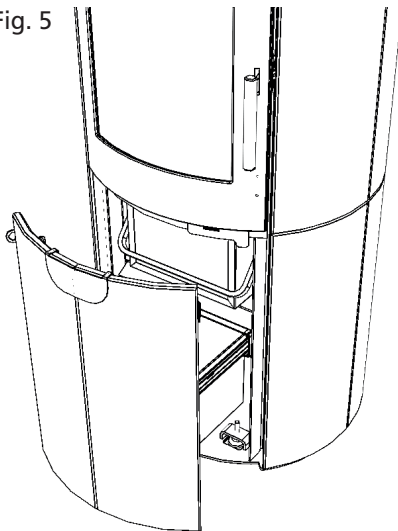

Changing flue outlet position from top to rear

The stove flue outlet position must be changed to the rear position before installing the cladding. It is a good idea to remove the two heat storage stones before making the change. Swap the flue outlet connector with the blanking plate on the rear.

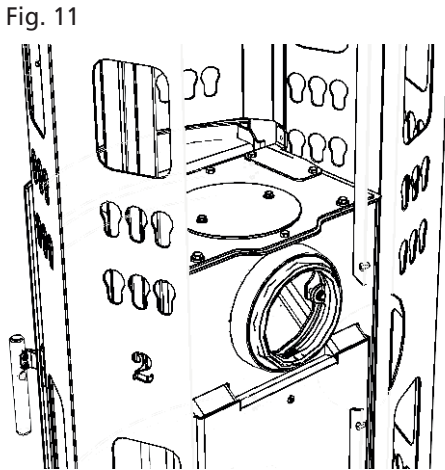
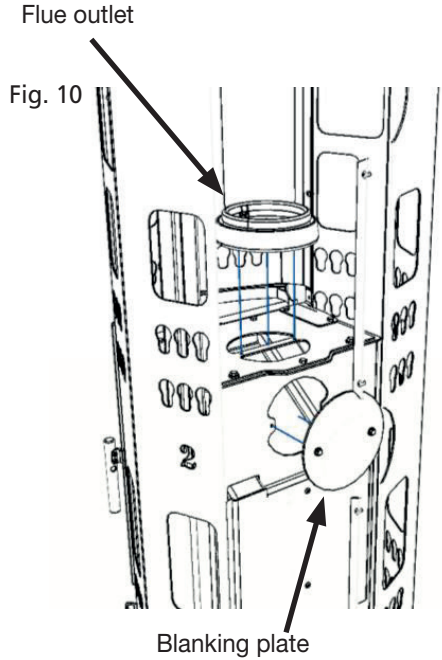

After swapping the flue outlet connector and blanking plate, the stove is ready for rear flue connection.

For top flue outlet

Cut the small metal bridge connecting the cover to the convection vent.

Fig. 12

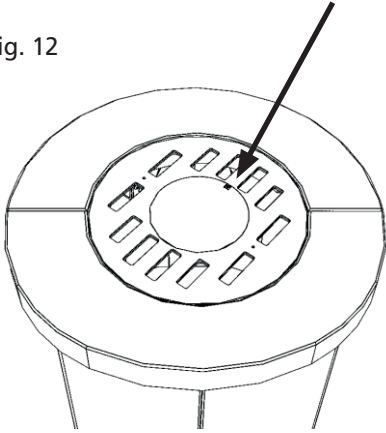
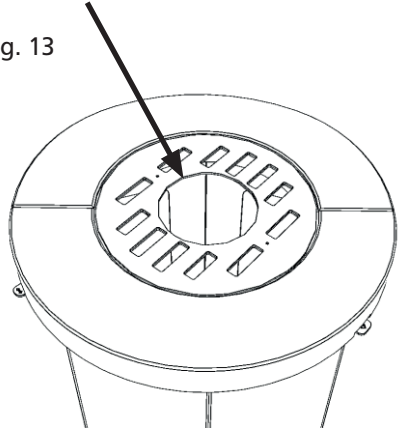

Fig. 13



For rear flue outlet

If the rear flue outlet is being used, the cover in the convection vent must NOT be removed. The cladding must be positioned with holes at the top, in line with the installation instructions for soapstone/ceramic Scan-Line 80 and 80XL stoves. The dimensions on the drawing below have been measured from the bottom edge of the backplate, and do not take into account the height of the adjustable feet.

Fig. 14

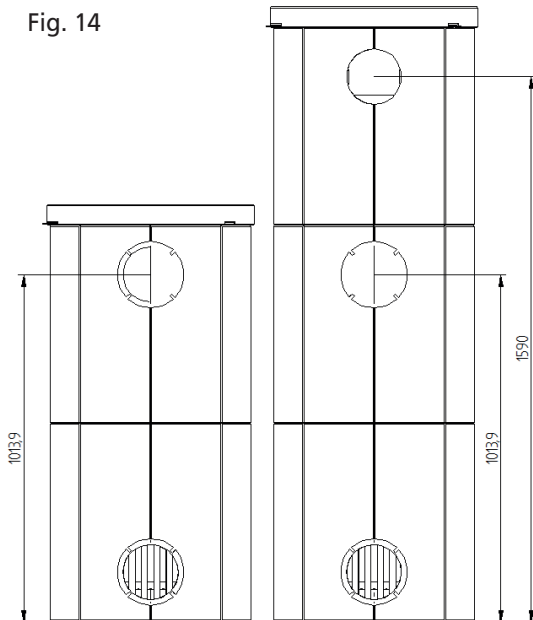

Cleaning after sweeping the chimney and replacing the stones. Fig 15-21



INSTALLING SOAPSTONE AND CERAMIC PANELS

Heta recommends that stove installation be carried out by two people.

The soapstone and ceramic panels must be handled with extreme care, as the corners and edges are very fragile.

If the rear flue outlet is to be used, it is best to change this before installing the cladding. See *the operating instructions for Scan-Line 80 and Scan-Line 80 XL*.

Before commencing installation, ensure that the stove is level.

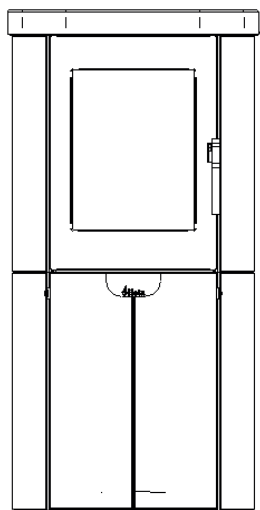

Scan-Line 80

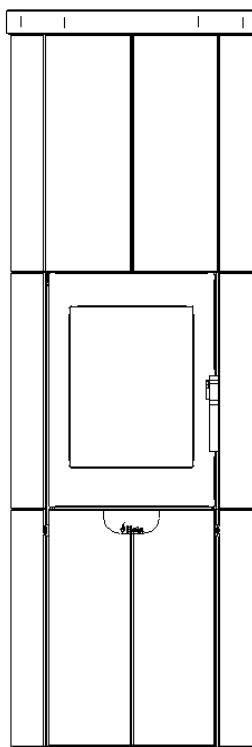

Scan-Line 80 XL

CLADDING TYPE AND PRODUCT NUMBERS

	Product no. soapstone	Product no. ceramic	Qty SL 80	Qty SL 80XL
A	0023-2277	0023-2288	1	1
B	0023-2278	0023-2289	1	1
C	0023-2279	0023-2290	2	2
D	0023-2280	0023-2291	2	2
E	0023-2281	0023-2292	8	14
F	0023-2282	0023-2293	-	2
G	0023-2283	0023-2294	2	2

The product numbers are shown on the rear sides of the elements.

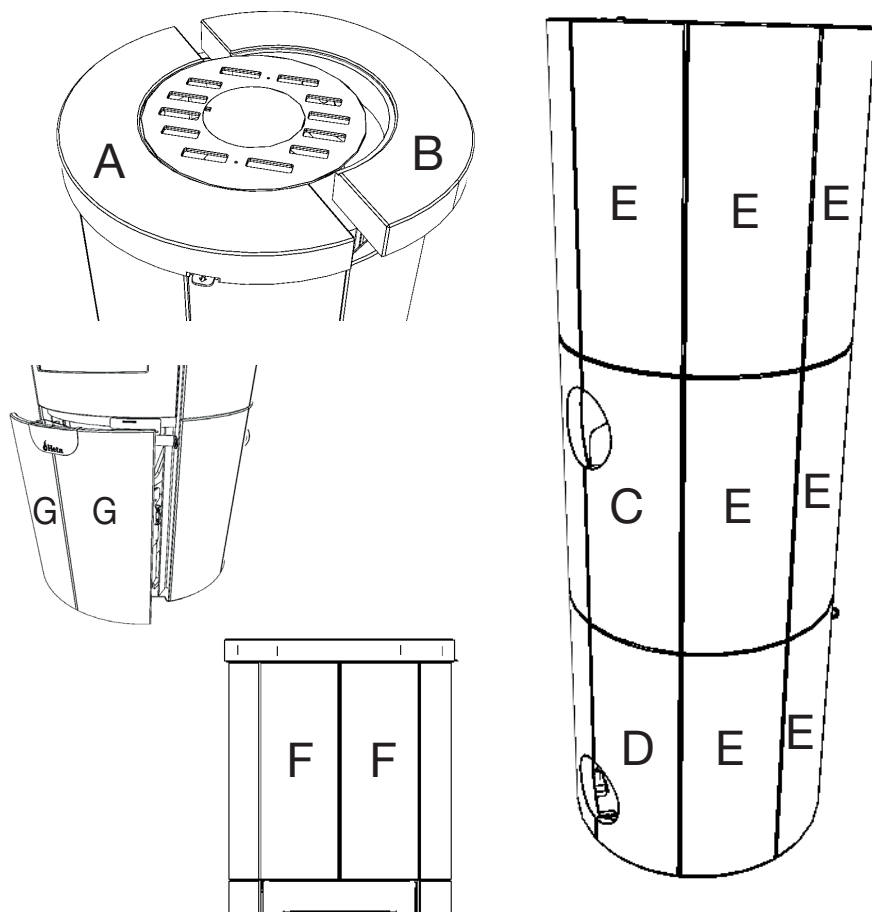

Remove the air adjustment lever before installing the cladding.
(10 mm spanner)

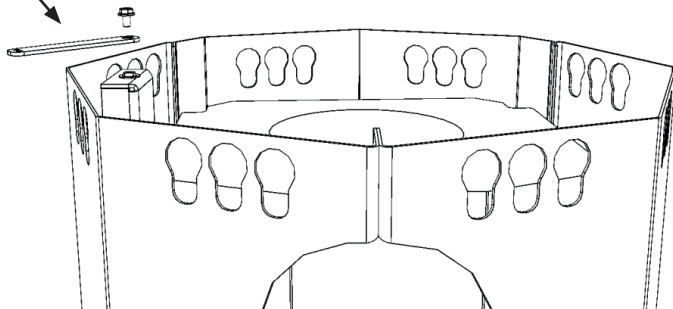

Start installing the cladding at the bottom rear section of the stove.
The first cladding stone (C or D) has a hole for outside air connection.

Place the cladding stone against the side panel and insert the mounting pegs (47 mm from the top of the cladding stone) in the large circular holes in the keyholes. Let the stone slide down so the pegs are at the bottom of the keyholes.

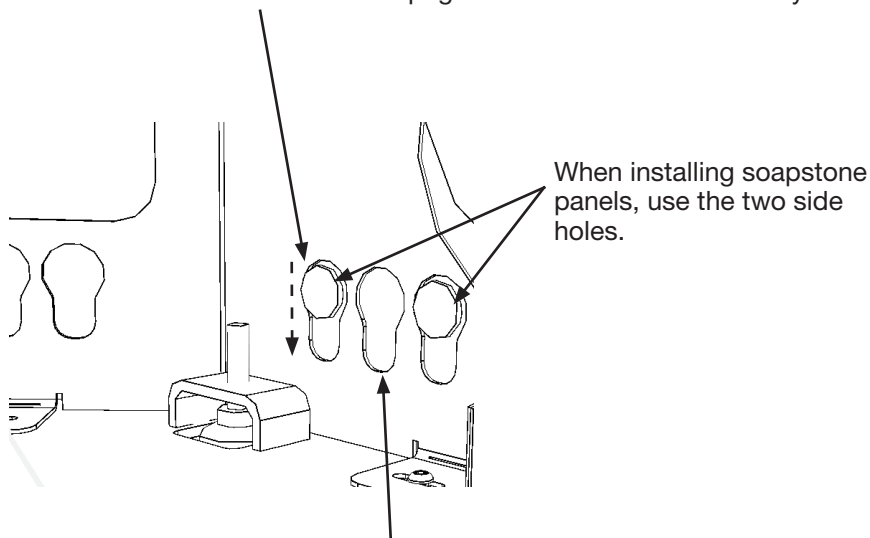

When installing soapstone panels, use the two side holes.

When installing ceramic panels, use the middle hole.

The mounting pegs should rest at the bottom of the keyholes when the cladding has been positioned correctly.

Install all the panels in the bottom row before starting on the second row of cladding stone.

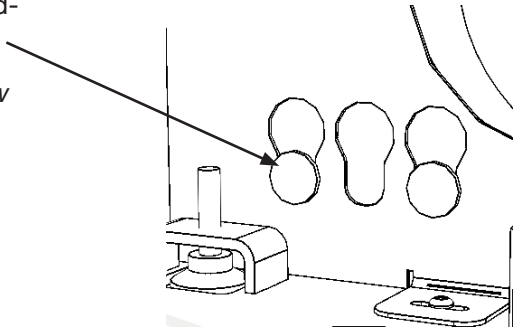

Stoves are shipped from the factory with a 1 mm gap between the side plates.

This gap can be adjusted using screws (4 on the SL 80 and 6 on the SL 80XL) to match the space between cladding panels C and D.

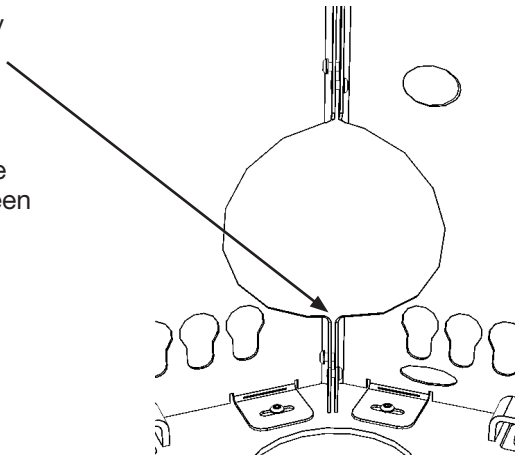

The soapstone panels have no fixed top or bottom, leaving you free to orient them how you wish.

Eight cladding stone panels (E) are used for the Scan-Line 80. These panels can be arranged however you want, as the same type of cladding stone panels are used on the opposite side of the stove.

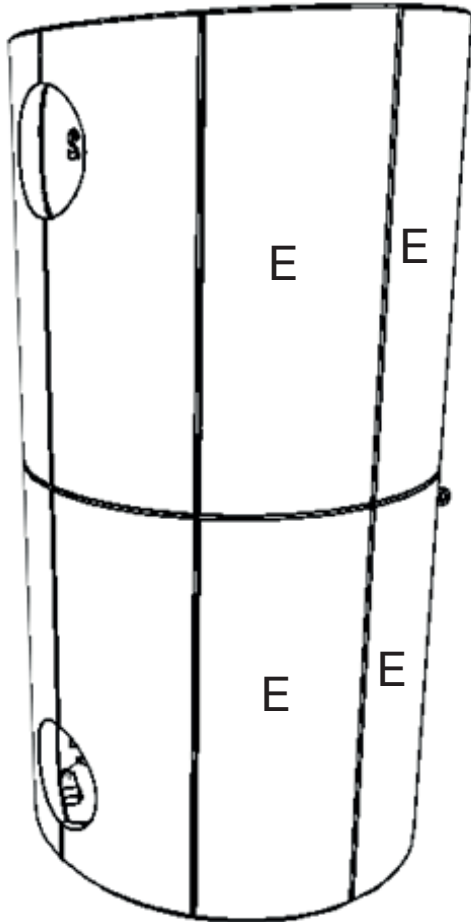

Fourteen cladding stone panels (E) are needed for the Scan-Line 80 XL. These panels can be arranged however you want, as the same type of cladding stone panels are used on the opposite side of the stove.

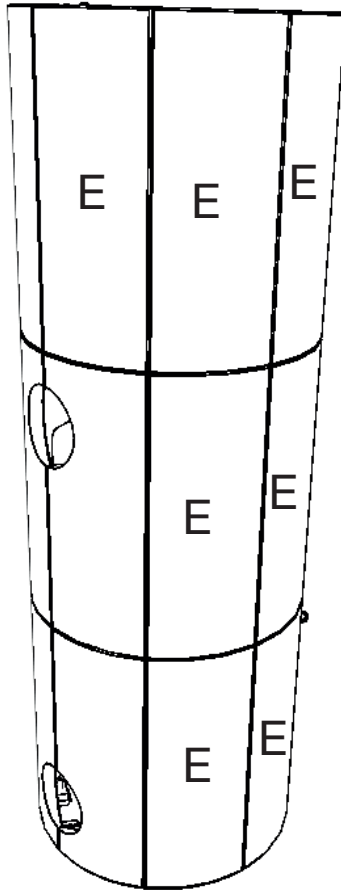

The panels will most likely require minor adjustment after installation (as soapstone is a natural stone, and there is a high tolerance in the production process for ceramic panels). Do this by pushing the soapstone/ceramic panels sideways until the distances between the cladding stones are equal.

Only sideways adjustment is possible.

These two cladding stones (F) are interchangeable.

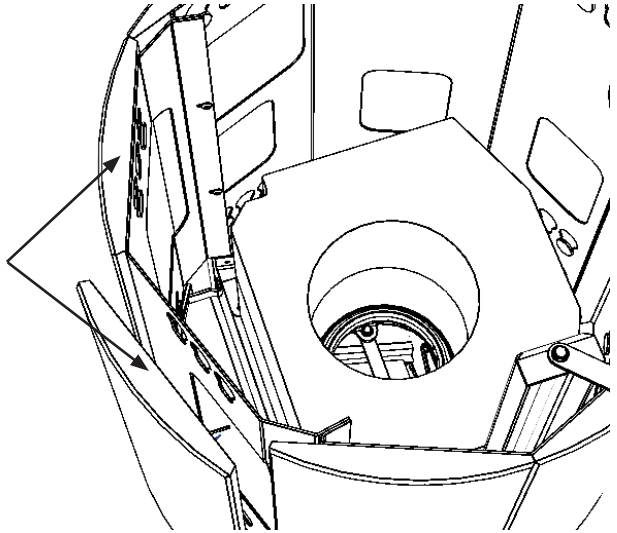

Once the cladding stones (E) have been installed, install the top front stones (F). Follow the same procedure as for the other cladding stones, except that the distance from the top of the cladding stones to the mounting pegs is 55 mm.
Applies only to the SL 80 XL!!!

These two brackets may need to be adjusted up or down to adjust the height of the soapstone/ceramic panels.

This can be done using pliers or a hammer.

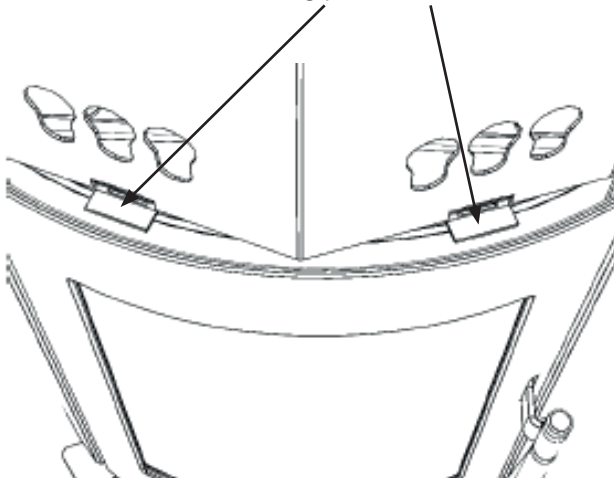

The soapstone/ceramic panels may need to be adjusted to be level with the cladding stones on the sides of the stove. Do this by loosening the four screws, two on each side. (*use a 4 mm hex key*)

Start by loosening the bottom two screws while the cladding is attached. Push the cladding in or out as required. Do the same with the top two screws. **Applies only to the SL 80 XL!!!**

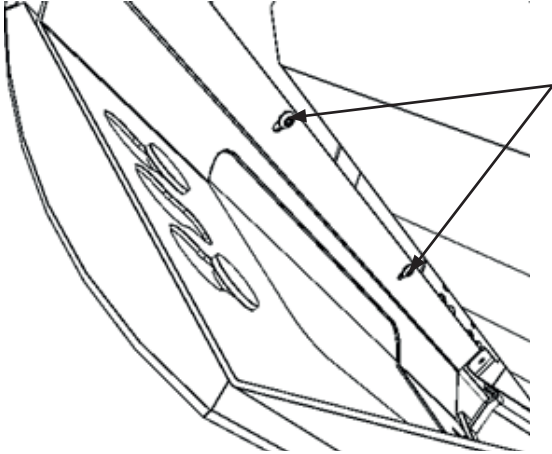

There are two screws on each side for adjusting the front panel/front stone.

These two brackets may need to be adjusted up or down to adjust the height of the soapstone/ceramic panels in relation to the door.

This can be done using pliers or a hammer.

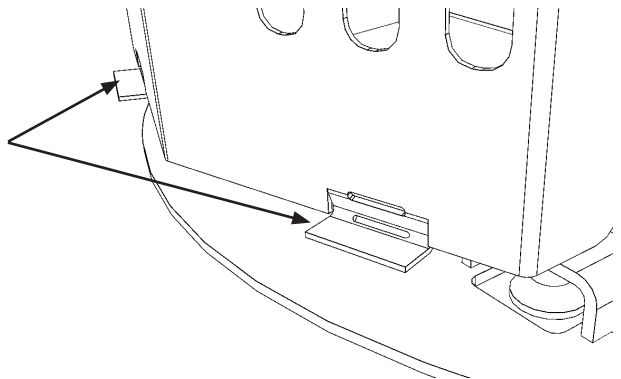

Install the front stones near the door (G) following the same procedure as for the other stones. Pull the door out slightly before installation. These stones are also interchangeable.

Install the sign afterwards (only on the soapstone model).

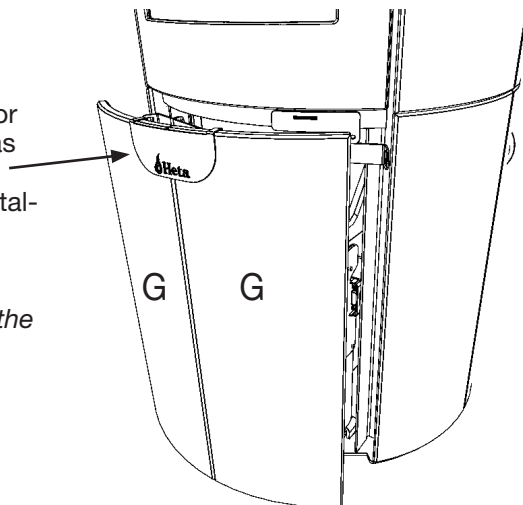

These two cover plates should be installed once the cladding stones have been installed. Cover plate 1027-0381 is not used if the rear flue outlet is being used.

Cover plate 1027-0378 is not used if the outside air connection is being used.

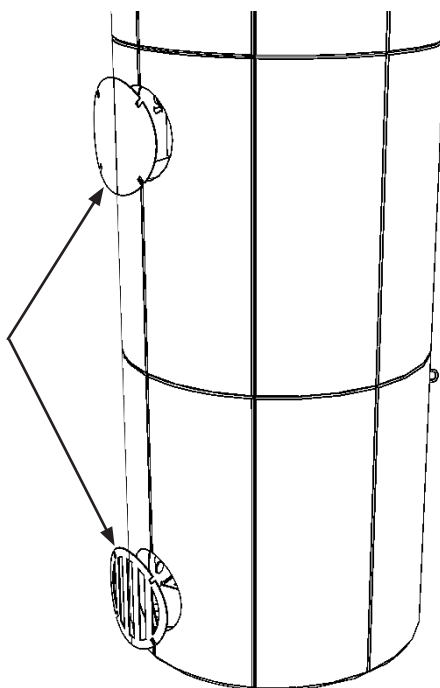

If there is an outside air connection, a flexible hose can be run from the air adjustment valve to the air outlet on the back of the stove.

It is also possible to run the external air connection up through the floor using a flexible hose.

A flexible hose is not included but can be purchased separately.

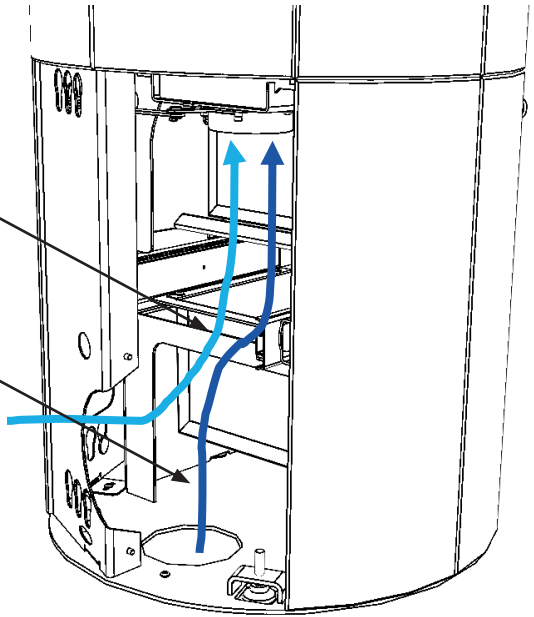

There is space for up to four 0023-0121 thermastones near the top flue outlet on the Scan-Line 80 XL, which can be installed before or after the cladding is installed.

The Scan-Line 80 XL is shipped from the factory with two thermastones. The other two can be purchased as optional extras. Remove the transportation bracket before using the stove or installing additional thermastones.

The Scan-Line 80 has no thermastones.

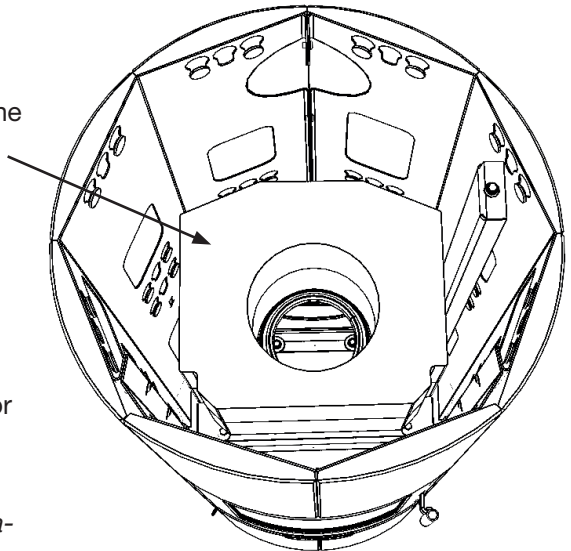

Screw the air adjustment lever back into place after installing the side cladding, before installing the top cladding.

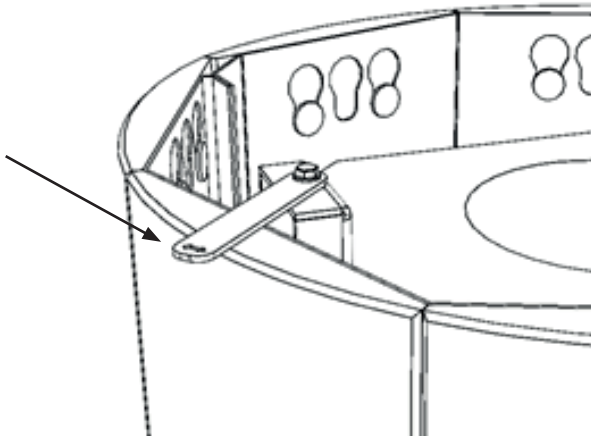

When installing the top cladding, place (A) first.

Then install (B)

Finally, install the convection top panel (see next page)

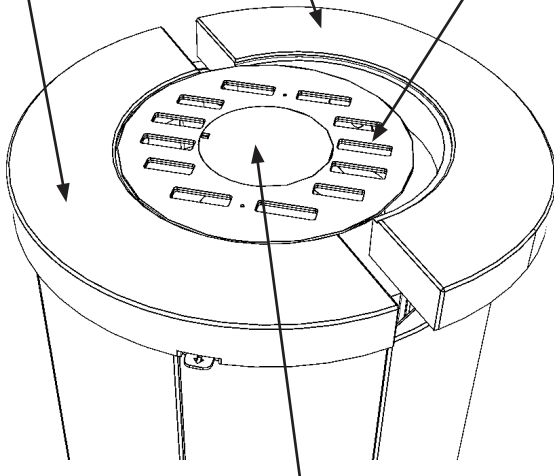

If the top flue outlet is being used, remove the centre cover plate using pliers.

Install the convection top panel as follows:

- 1: push (x) into the slot (y) in the top stone.
- 2: then push (z) into position in the hole between the top stones.

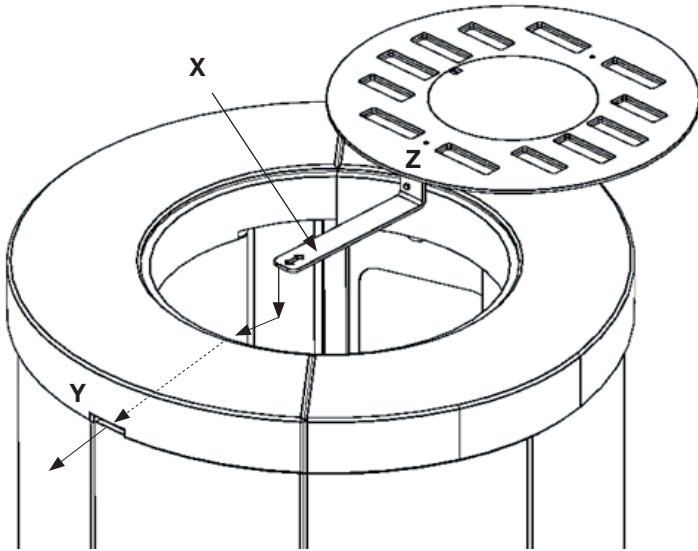

Correct installation of the convection top panel and top cladding.

